

# SGP 2332 / 4332 Fully Automatic Strapping Machine



## Standard Equipment

- Adjustable conveyor height
- Fold-out belt conveyor system
- Four swivel castors with brakes
- Closed strap arch system
- Heat seal
- Automatic strap feeder
- Automatic strap and ejection
- Strap loop ejection for cycles without product
- Cycle counter
- Electronic control system with microprocessor + Siemens S7-1200 PLC, free memory capacity for peripheral modules
- Machine-stop button
- Dispenser position: Side mounted
- Electrical power cable, 5m
- Basic photocell for detecting and positioning the package



Sigma Supply of North America, Inc.  
824 Mid America Boulevard, Hot Springs, AR 71913

Phone: 501-760-1511  
Fax: 501-760-1521  
www.sigmasupply.com  
equipment@sigmasupply.com

# SGP 2332 / 4332

## Technical Data / Layout

### Technical Data

Heat weld sealing	
Preheating time	30 s
Electrical supply	Single phase AC 230 V / 50 Hz, 1PH and 115 V / 60 Hz, 1PH Tolerance -15%/+20% Main fuse 10 A

Performance at 225VAC	Mode Sleep	Mode Stand-by	Mode Oper.Max
Watt	50 W	607 W	70 W
Volt Amp	53 VA	622 VA	78 VA
Reactive Power	19 VAR	193 VAR	33 VAR
Power Factor	PF 0.61	PF 0.98	PF 0.82
COS Phi	0.94	0.99	0.91
Amp	0.28 A	3.0 A	0.38 A

### Arch Dimension

Machines	Strap Width	Arch Dimension (WxH)	Strap Tension
SGP 2332 / 4332	5 mm (1/4") 9 / 12 mm (3/8" / 1/2")	650 x 500 mm (26 x 20") 650 x 500 mm (26 x 20")	300 N 450 N

Room temperature	5 - 40°C	(41 - 104°F)
Relative humidity	10 - 85%	
Cycles per minute up to* (without conveyor)	70/min.	
Conveyor	driven conveyor belt	
Conveyor speed, stepless	5 - 45 m/min (5.5 - 50 yd/min)	
Working heights	see layout	
Machine weight	300 kg	(660 lbs)
Color	stainless steel	
IP- Protection level	IP 56 / DIN 60529 + IPX9K / ISO 20653	

### Packages

Width x height min.	100 x 50 mm	(4 x 2")
Width / height max.,	.750 mm	(.72")
Arch dimension		
Length min.	--	(8")
Weight max.	35 kg	(77 lbs)

### Plastic Strap (PP)

Strap width	5 mm	(1/4")
	9 mm	(3/8")
	12 mm	(1/2")
Strap thickness	0.40 - 0.60 mm	(0.015 - 0.024")
Strap coil, Ø inside/outside	200 / 430 mm	(8" / 17")
Strap tension 5 mm (1/4")	300 N	
9 - 12 mm (3/8 / 1/2")	450 N	

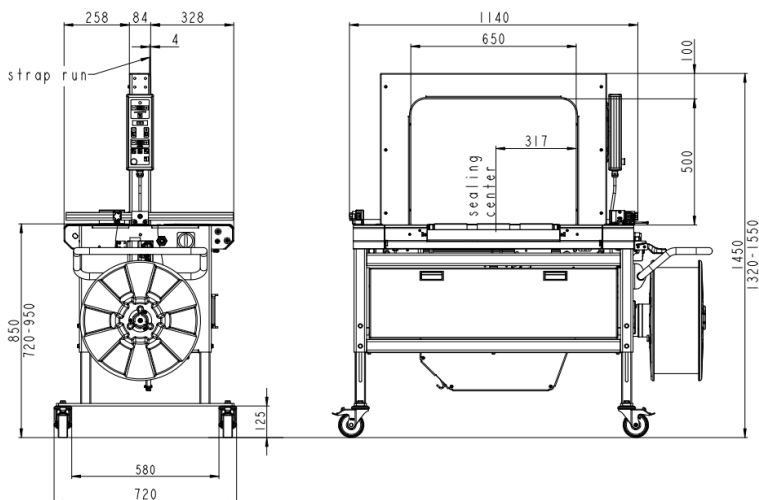

The polypropylene straps used for the respective applications must correspond with the strap specifications recommended by Signode!  
\*Performance: Depends on arch and package dimensions, conveyor speed, package distances and strap tension.